

Installation Instructions For Pressure Balance Valve

Recommended for all SH-PB Series Shower Fittings

CHICAGO FAUCETS 

a Geberit company

Notice to the Installer

- Read this entire instruction sheet before installing to ensure proper installation.
- Installation must comply with local codes and ordinances.

Pressurized plumbing fixtures shall be installed in accordance with manufacturer's recommendations. The supply piping to these devices shall be securely anchored to the building structure to prevent installed device from unnecessary movement when operated by the user. Care shall be exercised when installing the device to prevent marring the exposed surface.

NOTE: The information in this manual is subject to change without notice.

Please leave this manual with the facility manager after completing the valve installation. This document contains information necessary for routine maintenance and servicing.

Rough-In of Valve and Assembly of Trim

1. Rough valve body into wall, connecting piping to 1/2" female copper sockets or 1/2" male I.P. nipples (see **Figure 1**). **Important: note "UP" and "DOWN" markings on back of valve.**
2. The depth of rough-in should account for thickness of wall materials to be used (combined thickness of wall board and finished wall material). Face of guard should be positioned to be flush with finished wall surface (see **Figure 2**).
3. Anchor installation to bracing between studs (ears on the valve body can be used for this by removing the plastic guard). Otherwise, anchor the connection piping.
4. Valve should be pressurized and tested for leaks at the connections.
5. Plastic guard should be left attached to the valve until finished the wall material is installed.
6. After wall is finished, remove plastic guard and replace with trim sleeve and escutcheon plate (see **Figure 3**). Orient handle so that lever is pointed down toward "OFF" position.

IMPORTANT! Setting Hot Limit Stop

The removal of the warning label on the face of this mixing valve constitutes the transfer of liability from the manufacturer to the installer under the laws of the United States. It is the installer's responsibility to set the maximum output temperature of the valve to no more than 120°F, in accordance with ASSE/ANSI Standard 1016-2011 dealing with individual thermostatic, pressure balancing, and combination pressure balancing and thermostatic control valves for individual fixtures, temperature limit setting.

To properly set the limit ring, you must use a thermometer or calibrated sensing device to accurately measure the outlet water temperature. The adjustment ring is positioned as follows:

1. Expose the top of the cartridge by removing the trim sleeve from the valve body. Do **not** remove the hex nut holding it in place.
2. Remove the grey adjustment ring by placing the blade of a knife into the groove and prying it off (see **Figure 4**).
3. Note the stop tab on the bottom of the ring (see **Figure 5**). The further it is reoriented in a counter-clockwise direction, the shorter the travel allowed (and thus, the lower the temperature output possible). **Important: before re-orienting the ring, be sure the stem is in the full "OFF" position.**

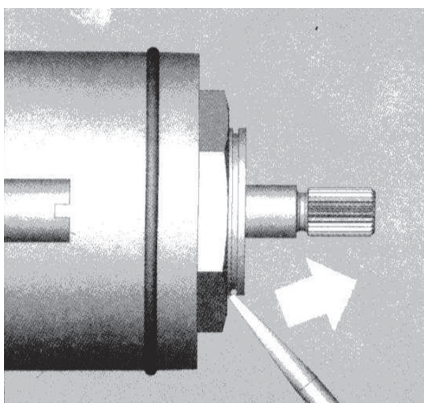

Figure 4

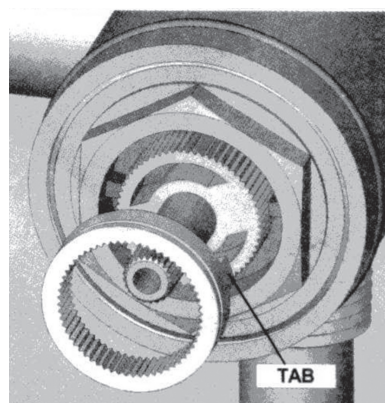

Figure 5

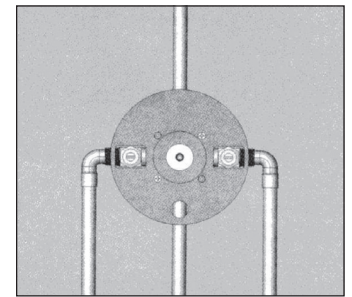

Figure 1

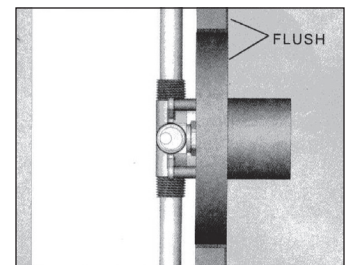

Figure 2

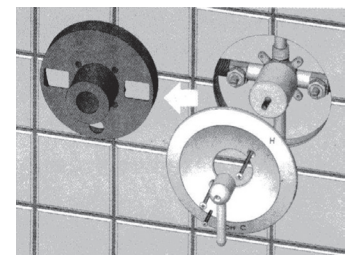

Figure 3

Installation Instructions For Pressure Balance Valve

(continued)

CHICAGO FAUCETS

a Geberit company

Reversing Cartridge For Back-to-Back Installations Only

When a valve is installed with reversed supply connections (typically in a back-to-back situation), the cartridge can be reversed to allow normal operation (see **Figure 6**).

1. Remove trim sleeve to expose top of valve.
2. Loosen and remove hex nut above cartridge.
3. Remove cartridge from valve cavity.
4. Look into cavity to see upper and lower locating holes for cartridge pin on the floor of the cavity.
5. Re-insert cartridge, aligning the pin with lower locating hole (partially cut away by discharge opening).
6. Press cartridge in firmly to assure that pin has been properly inserted.
7. Secure cartridge by tightly reassembling the hex nut.
8. Reassemble trim.

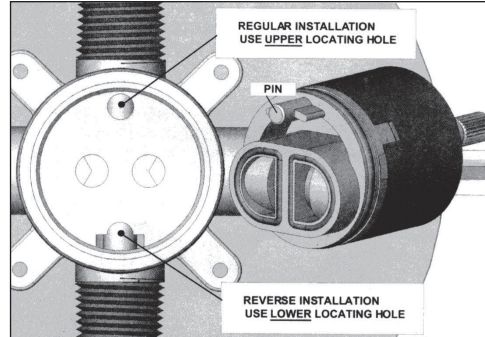

Figure 6

Replacing Cartridge

Same basic procedure as above (reverse if necessary).

Important Note for Tub/Shower Installations

To prevent dripping in the tub-fill mode, shower arm must be located a minimum of 36" above valve outlet (see **Figure 7**).

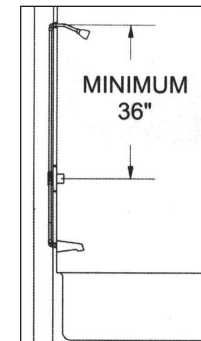

Figure 7

Care and Maintenance

All Chicago Faucets fittings are designed and engineered to meet or exceed industry performance standards. Care should be taken when cleaning this product. Do not use abrasive cleaners, chemicals or solvents as they can result in surface damage. Use mild soap with warm water for cleaning and protecting the surface of Chicago Faucets fittings.

For additional technical assistance, call 800/TEC-TRUE (800-832-8783) or visit our website at chicagofaucets.com.

CHICAGO FAUCETS LIMITED WARRANTY

TO WHOM DOES THIS WARRANTY APPLY? — The Company extends the following limited warranty to the original user only.

WHAT DOES THIS WARRANTY COVER AND HOW LONG DOES IT LAST? This warranty covers the following Commercial Products: SH-PB Shower Fittings.

LIFETIME FAUCET WARRANTY — The "Faucet," defined as any metal cast, forged, stamped or formed portion of the Product, not including electronic or moving parts or other products separately covered by this Limited Warranty or water restricting components or other components, is warranted against material manufacturing defects for the life of the Product.

FIVE YEAR FAUCET WARRANTY — Certain Products and portions of the Product are warranted against material manufacturing defects for a period of five (5) years from the date of Product purchase. Products warranted against material manufacturing defects for a period of five (5) years from the date of Product purchase are referred to by the product numbers 42X, 43X, 15XX and E-Tronic™ - 4X, 5X, 6X, 7X, 8X and 9X. All zinc die cast portions of Product are warranted against material manufacturing defects for a period of five (5) years from the date of Product purchase.

THREE YEAR ELECTRONICS WARRANTY — Electronic components, including the solenoid, are warranted for three (3) years from the date of installation.

FIVE YEAR CARTRIDGE WARRANTY — The "Cartridge", defined as the metal portion of any Product typically referred to by the product numbers containing 1-099, 1-100, 1-310, 377X, 217X and 274X, excluding any rubber or plastic components, is warranted against material manufacturing defects for a period of five (5) years from the date of Product purchase. All Cartridges included in the Company's Single Control or Shower Products also are warranted against material manufacturing defects for a period of five (5) years from the date of Product purchase.

ONE YEAR FINISH WARRANTY – COMMERCIAL — For Products used in commercial applications, the finish of the Product is warranted against material manufacturing defects for a period of one (1) year from the date of Product purchase.

OTHER WARRANTIES — All other Products not covered above are warranted against material manufacturing defects for a period of one (1) year from the date of Product purchase.

Other restrictions and limitations apply. For complete warranty details, call Chicago Faucets Customer Service at 847-803-5000 or visit chicagofaucets.com.

The Chicago Faucet Company
2100 South Clearwater Drive
Des Plaines, IL 60018
Phone: 847/803-5000
Fax: 847/803-5454
Technical: 800/832-8783
www.chicagofaucets.com